

Pile foundations – Introduction

Program: Pile, Pile CPT, Pile Group

The objective of this engineering manual is to explain the practical use of programs for the analysis of pile foundations in GEO 5.

The GEO 5 software suite contains three pile foundation analysis programs – **Pile, Pile CPT, and Pile Group**. The text below gives a more detailed explanation regarding which of the programs are to be used in particular conditions – each individual program is subsequently described in the following chapters.

Vertical load-bearing capacity of pile foundations is determined using various methods:

- **static pile test**: these tests are required in some countries, and structural analysis is only considered a preliminary pile foundation proposal;
- **analysis based on soil shear strength parameters**: using the analysis methods NAVFAC DM 7.2, Tomlinson, CSN 73 1002 and Effective stress in programs PILE and PILE GROUP;
- **analysis based on the assessment of penetration tests**: PILE CPT program;
- **analysis according to regression curve equations obtained from the results of static loading tests** (according to Masopust): PILE program; Vertical load-bearing capacity is determined from the pile loading curve for the corresponding (allowable) settlement (CSN 73 1002 standard specifies the corresponding settlement value $s_{lim} = 25.0 \text{ mm}$).
- **analysis based on Mohr-Coulomb parameters and stress-strain properties of soils**: using the so-called Spring Method in PILE and PILE GROUP programs;
- **numerical analysis using the Finite Element Method**: the FEM program.

As this list shows, piles can be assessed using many ways and on the basis of different input parameters. Therefore, while analysis results can be identical, they often differ significantly.

A great advantage of GEO 5 is the fact that the user can try more variants and analysis methods, find the most likely behavior of the pile foundation and then determine the total bearing capacity or settlement of a single pile or a pile group.

The vertical load-bearing capacity of pile foundations is assessed in GEO 5 programs only for the vertical normal force acting on the foundation (with the only exception: Pile Group – Spring Method). The horizontal forces acting on the foundation, bending, and torsional moments have no influence on the analysis of the vertical load-bearing capacity of piles.

Analysis of the vertical load-bearing capacity of a single pile in GEO 5 – Pile is presented in *Chapters 13 and 14*, an analysis of the same pile on the basis of CPT tests is described in *Chapter 15*.

Horizontal bearing capacity of pile foundations:

The result of the analysis of a horizontally loaded pile is the horizontal deformation of the pile and the curve for internal forces along the pile shaft.

In the case of a single pile, its horizontal deformation and reinforcement depend on the calculated modulus of the horizontal reaction of the subsoil and the loading by the lateral force or the bending moment. The analysis procedure is explained in *Chapter 16*. The analysis procedure for a pile group is presented in *Chapter 18*.

Settlement of pile foundations:

The real load-bearing capacity of a pile is directly associated with its settlement because of the fact that virtually any pile settles under a given load and gets vertically deformed.

The settlement of single piles is determined in the PILE program using the following methods:

- **according to Masopust** (non-linear): the program analyses the settlement of a single pile on the basis of the regression coefficients along the skin and under the base of the pile.
- **according to Poulos** (linear): the program analyses the value of the total settlement on the basis of the determined pile base bearing capacity R_b and the pile skin bearing capacity R_s .
- **by means of the Spring Method**: the program analyses the loading curve on the basis of the given parameters of soils using the Finite Element Method.

The PILE program constructs the loading curve (the so-called working diagram) for all of the methods.

The settlement of a pile group is described in *Chapter 17*, the settlement of piles designed on the basis of CPT penetration tests is presented in *Chapter 15*.

Program selection

1. **selection** based on the stiffness of the base slab (pile cap). When the pile cap is considered to be infinitely stiff, the Pile Group solution is used. In other cases, single piles are investigated.

2. **selection** based on the results of a geological survey. If the results of CPT tests are available, then the Pile CPT program is used to analyze the single pile or the pile group (see *Chapter 15*). In other cases, the program Pile (or Pile Group) is used for the solution, on the basis of given soil parameters.

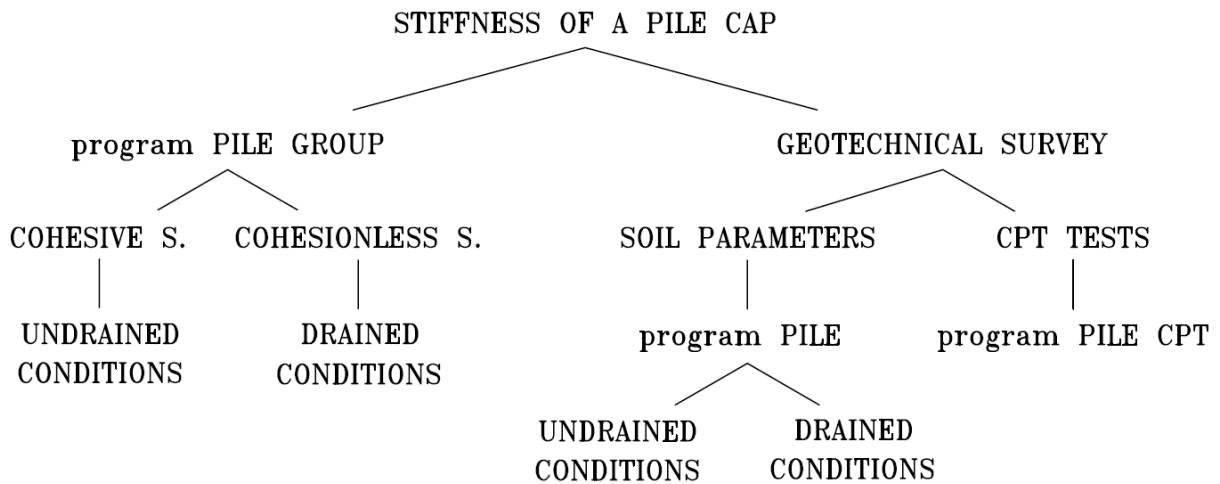

Based on the **type of the analysis** we distinguish:

- **analysis for drained conditions:** effective parameters of shear strength of soils φ_{ef}, c_{ef} are used in the Pile and Pile Group programs as a standard for analysis methods *CSN 73 1002* and *Effective stress*;

- **analysis for undrained conditions:** only the value of the total soil cohesion c_u is set in the Pile and Pile Group programs. The vertical load-bearing capacity of a single pile is

determined according to *Tomlinson*, whilst a pile group is analyzed as the load-bearing capacity of a soil cylinder (block) according to *the FHWA*.

The NAVFAC DM 7.2 method combines both of the aforementioned analysis procedures. It is possible to choose whether each of the soil layers will be considered as drained (cohesionless) or undrained (cohesive).

General task specification:

Analyze the vertical load-bearing capacity and settlement of a pile foundation (see the schema below) in the set geological profile; further, determine the horizontal deformation of the piles and propose reinforcement for individual piles. The pile foundation consists of four bored piles with diameter $d = 1.0 \text{ m}$ and length $l = 12.0 \text{ m}$. The resultant force of the total loading N, M_y, H_x acts at the upper surface level of the foundation slab (pile cap) namely in the slab center. C 20/25 reinforced concrete is used for the piles.

Load acting on the piles

To simplify the problem, we will always consider 1 loading case in the program.

The determination of loads acting on the pile foundation is different depending on the structure type and subsequent solution, i.e., whether we solve a single pile or a pile group.

Pile Group

We assume that the slab joining the piles is stiff. In our case, we will consider a pile cap with thickness $t = 1.0 \text{ m}$. In this case, we determine the total reaction in the pile cap center.

Note: A simple method of obtaining loads on a pile group using any of the static programs is described in the program help for the Pile Group program "[Determination of loading on a pile group](#)".

a) Design (calculation) loads:

- Vertical normal force: $N = 5680 \text{ kN}$,
- Bending moment: $M_y = 480 \text{ kNm}$,
- Horizontal force $H_x = 310 \text{ kN}$.

b) Imposed (working) loads:

- Vertical normal force: $N = 4000\text{ kN}$,
- Bending moment: $M_y = 320\text{ kNm}$,
- Horizontal force: $H_x = 240\text{ kN}$.

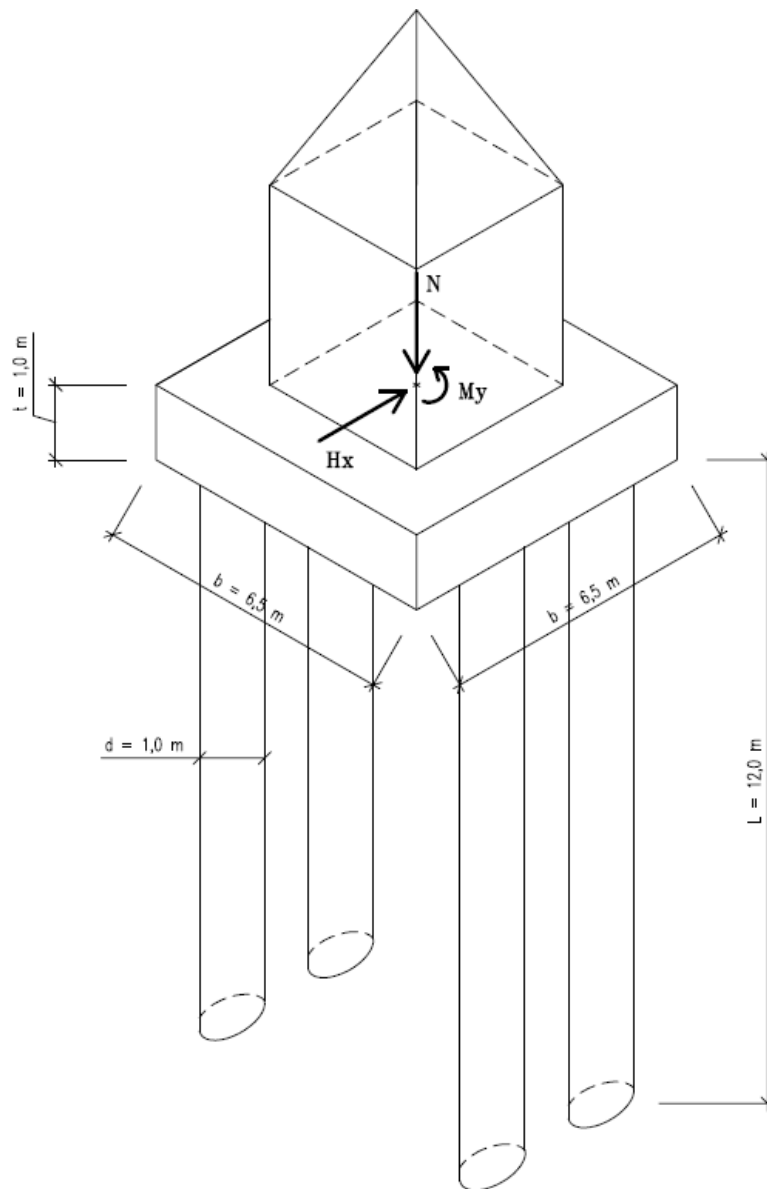

Problem specification schema – pile foundation

Single piles

If the slab is soft in bending (non-stiff) or the building is founded on a pile cap, the structural diagram is different, and we will obtain reactions at the heads of individual piles from a static program (e.g. GEO 5 – Plate, FIN 3D, SCIA Engineer, Dlubal RStab, etc.).

In this example, we will carry out the pile analysis using only 1 loading case for simplification.

a) Design loading:

- Vertical normal force: $N_1 = 1450 \text{ kN}$,
- Bending moment: $M_{y,1} = 120 \text{ kNm}$,
- Horizontal force: $H_{x,1} = 85 \text{ kN}$.

b) Service loading:

- Vertical normal force: $N_1 = 1015 \text{ kN}$,
- Bending moment: $M_{y,1} = 80 \text{ kNm}$,
- Horizontal force: $H_{x,1} = 60 \text{ kN}$.

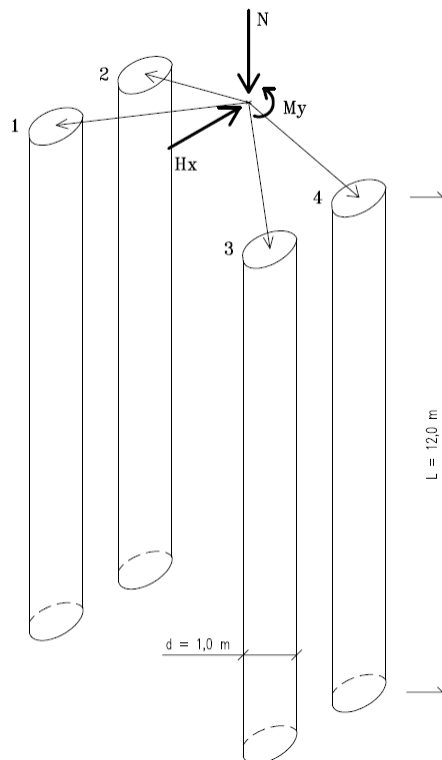

Loads action schema – load distribution among individual single piles

Note: If we assume identical dimensions and reinforcement of the piles, we can assess all piles as one pile with loading combinations acting on all piles.

Geological profile

- 0,0 to 6,0 m: Sandy Clay (CS, consistency firm),
- above 6,0 m: Sand with trace of fines (S-F, medium dense soil).

Note: The basic soil parameters are the same as when performing the analysis of single piles and for the verification of a pile group. Their values are given in the following table.

Soil parameters / Classification	Sandy Clay (CS) consistency firm	Sand with trace of fines (S-F) medium dense soil
Unit weight γ [kN/m^3]	18,5	17,5
Unit weight of satur. soil γ_{sat} [kN/m^3]	20,5	19,5
Cohesion of soil c_{ef} / c_u [kPa]	14,0 / 50,0	0 / 0
Angle of internal friction φ_{ef} [$^\circ$]	24,5	29,5
Adhesion factor α [-]	0,6	–
Bearing capacity coefficient β_p [-]	0,3	0,45
Poisson's ratio ν [-]	0,35	0,3
Oedometric modulus E_{oed} [MPa]	8,0	21,0
Deformation modulus E_{def} [MPa]	5,0	15,5
Type of soil	Clay (cohesive soil)	Sand, gravel (cohesionless soil)
Angle of dispersion β [-]	10,0	15,0
Coefficient k [MN/m^3]	60,0	150,0
Modulus of horizont. comp. n_h [MN/m^3]	–	4,5
Modulus of elasticity E [MPa]	5,0	15,5

Table with the soil parameters – pile foundations (summary)

List of chapters related to pile foundations:

- Chapter 12: Pile foundations – introduction

- *Chapter 13:* Analysis of vertical load-bearing capacity of a single pile
- *Chapter 14:* Analysis of single pile settlement
- *Chapter 15:* CPT tests based pile analysis
- *Chapter 16:* Analysis of horizontal load-bearing capacity of a single pile
- *Chapter 17:* Analysis of vertical load-bearing capacity and settlement of a pile group
- *Chapter 18:* Analysis of deformation and pile group dimensioning.
- *Chapter 36:* Verification of a Micropile Foundation